

# Comparative Analysis of Several Incremental Conductance MPPT Techniques for Photovoltaic System

Khadija Saidi <sup>#1</sup>, Mountassar Maamoun <sup>#2</sup>, M'hamed Bounekhla <sup>#3</sup>

<sup>#</sup>Electronics Department, Blida\_1 University  
BP 270, Blida, Algeria

<sup>1</sup>saidikhadija@yahoo.fr

<sup>2</sup>mountassar.maamoun@gmail.com

<sup>3</sup>bounekhla.mhamed@yahoo.fr

**Abstract**— The maximum power point tracking (MPPT) technique is used in photovoltaic systems to extract the maximum power. The most popular MPPT technique is the incremental conductance because it is less complicated and has a good tracking accuracy.

This work is an attempt to study and discuss four types of the incremental conductance method, namely: Incremental Conductance with fixed step size (FS\_IC), Incremental Conductance with variable step size (VS\_IC), Incremental Conductance with first proposition of modified variable step size (MVS1\_IC) and Incremental Conductance with second proposition of modified variable step size (MVS2\_IC), these four techniques are simulated by Psim software. Results show the good tracking efficiency of the MVS1\_IC and MVS2\_IC techniques compared to FS\_IC and VS\_IC, also the MVS2\_IC MPPT algorithm is the most efficient and presented less energy loss.

**Keywords**— Incremental Conductance, MPPT, Photovoltaic (PV),

## I. INTRODUCTION

In recent years, the growing demand for energy and pollution from the use of fossil fuels are driving the general public to use renewable energies. In this context, photovoltaic energy is one of the important sources of renewable energy which presents an outcome to our problems of energy production. Photovoltaic solar energy comes from the direct transformation of part of the solar radiation into electrical energy. This conversion of energy takes place via a photovoltaic cell. The association of several PV cells in series / parallel gives rise to a photovoltaic generator (PVG) which has a not-linear current-voltage characteristic (I-V) and has a maximum power point (MPP) [1],[2]. The transfer of the maximum power of the photovoltaic generator (GPV) to the load often suffers from poor adaptation. The literature proposes a large quantity of solutions on the control algorithm which performs a maximum power point track when the GPV is coupled to a load through a static converter [3]. In this context, the MPPT controller is the most appropriate method for optimize system efficiency.

Several MPPT techniques have been reported in the literature such as Perturb and Observe (P&O) [4], [5], Incremental Conductance (InC) [6], [7], particle swarm optimization (PSO) [8], [9], ant colony optimization (ACO) [10], Neural Network [11], and fuzzy logic control [12], [13].

Incremental inductance method present one of the best controller of DC-DC converter, it is less complicated and has good tracking accuracy [14]. In recent years, various MPPT techniques of incremental conductance have been suggested, namely: the fixed step size incremental conductance technique (FS\_IC) [15] and the variable step size incremental conductance technique (VS\_IC). The first one used a fixed step size to follow the MPP, this later is reached when the slope of P-V curves is zero. Thus, the accuracy and speed of the response time are highly dependent on the defined step size: if the step size is low, the accuracy is high and the speed response is so slow, but situation is reversed with a larger step size.

To overcome this problem, a second technique VS\_IC with direct control is proposed [16],[17], but it presents some defaults corrected by others techniques named modified variable step size incremental conductance technique (MVS\_IV).

In this article, a comparison analysis of various incremental conductance MPPT techniques has been provided and presented using PSIM software from POWERSIM corp, which provides a powerful and efficient environment for power electronics simulation needs.

## II. PHOTOVOLTAIC SYSTEM

A photovoltaic system consists of three parts as shown in Fig. 1. The first one represents the photovoltaic generator, the second part is a DC-DC converter controlled by MPPT controller. The third part represents the load [1].

### A. Pv Generator

A physical model of Solarex MSX-60 PV pannel proposed by Psim software is represented in Fig. 2. The electrical characteristics of this pannel is shown in Table I.

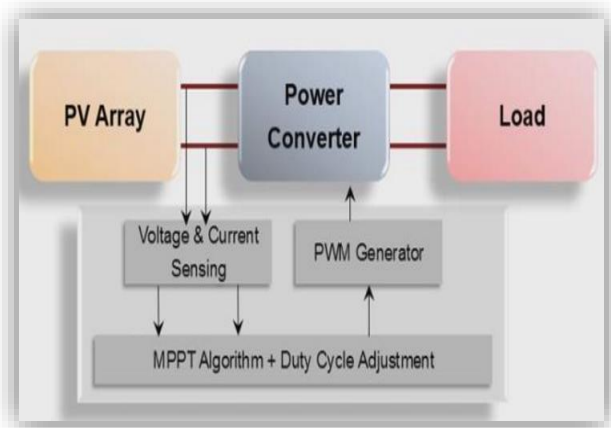

Fig. 1 Photovoltaic system block diagram.

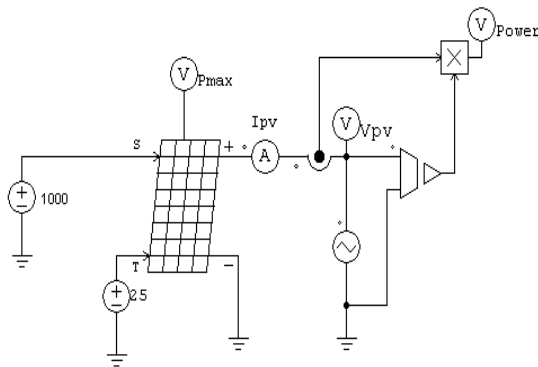

Fig. 2 Photovoltaic model of PVG in Psim.

TABLE I  
 ELECTRICAL CHARACTERISTICS OF SOLAREX MSX-60  
 (1kW/M<sup>2</sup>, 25 °C)

Description	MSX-60
Maximum power (Pm)	60W
Voltage Pmax (Vmpp)	17.1V
Current at Pmax (Impp)	3.5A
Short circuit current (Isc)	3.8A
Open circuit voltage (Voc)	21.1V
Temperature coeff. of Voc	-(80±10)mV/°C
Temperature coeff. of Isc	(0.065±0.01)%/°C
Temperature coeff. of power	(-0.5±0.05)%/°C
Nominal operating cell temperature NOCT2	47±2 °C

### B. Power converter

In order to extract the maximum power from the PV module, it is necessary to adapt the PV panel to the load. This adaptation is carried out by means of the DC-DC converter [13],[18].

The model that we have chosen in our study is a buck converter shown in Fig. 3.

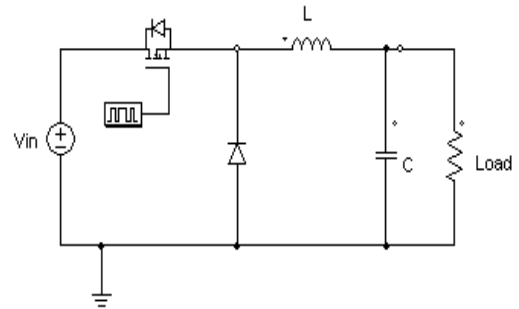

Fig. 3 DC-DC buck converter circuit.

### C. Incremental conductance MPPT method

In general, the conventional algorithm IC MPPT uses a fixed step to follow the maximum power point, in this case it is called fixed step size incremental conductance MPPT technique (FS\_IC), this technique presents drawbacks which are corrected by the development of another technique with a variable step size named variable step size incremental conductance MPPT technique (VS\_IC). Fig. 4 illustrates a manner of tracking the MPP using variable step size increment [14],[19].

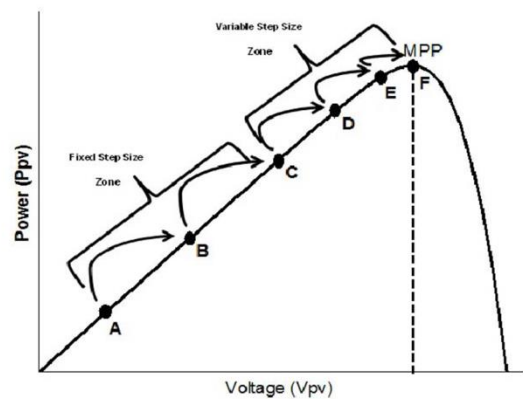

Fig. 4 A manner of tracking the MPP with variable step size increment.

#### 1) Incremental conductance method with fixed step size (FS\_IC)

The algorithm of this method measures at first the voltage V and the current I from the photovoltaic generator (PVG), the second state is to calculate the output power P and its derivative as a function of the voltage  $dP/dV$ . The third state is to use the derivative of the power-voltage output characteristic to decide whether the duty cycle should be increased or decreased [14],[15]. The flow chart of the FS\_IC algorithm is shown in Fig. 5.

The output power and its derivative is given by following equations:

$$P = V \cdot I \quad (1)$$

$$dP = d(V \cdot I) \quad (2)$$

The  $dP/dV$  ratio can be expressed as:

$$dP/dV = I + V (dI/dV) \quad (3)$$

The  $dP/dV$  is defined as the maximum power point identification factor used for tracking the MPP. The following equations are considered to track the MPP [14],[15].

$$dI/dV = -I/V \text{ at MPP}, \quad (4)$$

$$dI/dV > -I/V \text{ at left of MPP} \quad (5)$$

$$dI/dV < -I/V \text{ at right of MPP} \quad (6)$$

The disadvantage of IC method with a fixed increment is that if we use a large increment, the MPP search is faster, but it causes excessive oscillations around the PPM, which produces a low yield [19]. This situation is reversed when the increment step is small. To solve this problem, several IC algorithms of variable step size are presented in the literature [20],[21].

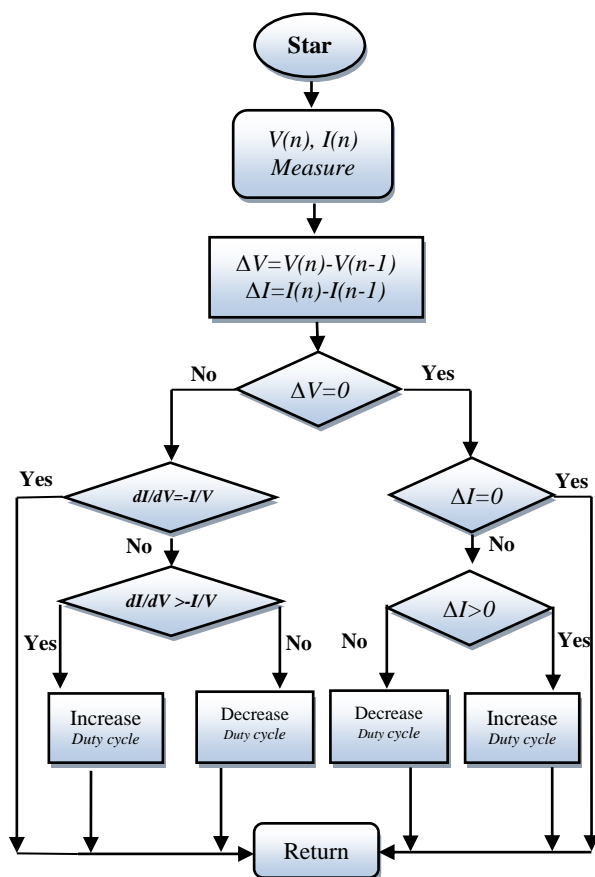

Fig. 5 Flow chart of IC method with fixed step size.

### 2) Incremental conductance method with variable step size (VS\_IC)

Different IC MPPT algorithms with variable increment steps are proposed in the literature. The principle of this algorithm is that if the operating point is far from MPP, it

increases the increment step size which allows a fast tracking of the MPP whereas if the operating point is near to the MPP, the step size becomes very small so the oscillation becomes very reduced contributing to a higher efficiency [22],[23]. The variable step size adopted to reduce this problem is represented as follow [24]:

$$Step = N \left| \frac{dP}{dV} \right| \quad (7)$$

Where:

$N$  is the scale factor that is set during the design to adjust the step size. To increase the convergence of this algorithm the variable step size must satisfy the following inequality:

$$N \left| \frac{dP}{dV} \right| < \Delta D_{max} \quad (8)$$

Where:

$\Delta D_{max}$  is the largest step size for FS\_IC MPPT. The scaling factor can be obtained as:

$$N < \Delta D_{max} / \left| \frac{dP}{dV} \right| \quad (9)$$

When equation 9 cannot be satisfied, the increment step takes the maximum value of the fixed step  $\Delta D_{max}$  previously set. This method can increase the speed of convergence and also reduce oscillations in steady state [15],[24].

According to equation 8 the  $dP/dV$  is all time compared to a constant ( $\Delta D_{max}/N$  is constant).

As shown in Figure 6, curve  $P1$  and  $P2$  are the output power of a PV array under different irradiation levels. The scaling factor  $N1$  and upper limiter step size  $\Delta D_{max1}$  are chosen by reference to  $P1$ ; in this case, fast dynamic response and good steady performance are achieved simultaneously. However, when irradiation changes greatly, the same parameters always make the system operate within the variable step size mode for  $P2$  curve, which increases the start-up time, as well as the response time. If the scaling factor  $N2$  and upper limiter of step size  $\Delta D_{max2}$  are selected according to power curve  $P2$ , the variable step size area of the system that worked for  $P1$  curve becomes too small, which incurs severe oscillations at steady state and continuous power loss. All in all, the parameters have a significant effect on the system performance, and a poor choice may lead to inefficiency or failure during start-up or dynamic tracking. It is then impossible to find suitable scaling factor and upper limiter of step size that satisfy the requirements of the MPPT system under enormous irradiance changes.

### 3) Incremental conductance method with modified variable step size (MVS1\_IC) -first proposition-

The main idea of the MVS1\_IC method is that the fixed line ( $\Delta D_{max} / N$ ) of Fig. 6 should move up and down when the sun's radiation level changes between  $P1$  and  $P2$ .

Since the change in the level of irradiation of the sun is strongly related to the output current of the PV generator [24]. Equation 7 is modified as follows:

$$Step = \frac{N}{I} \left| \frac{dP}{dV} \right| \quad (10)$$

Equation 10 shows that the  $|dP/dV|$  is compared to a variable coefficient which varies as a function of the output current of the PV module. [15], [24].

4) Incremental conductance method with modified variable step size (MVS2\_IC) -second proposition-

This technique has the same principle as the MVS1\_IC, but the difference is in the introduction of the  $dI$  term instead of the current value  $I$  in the equation 7 [17]. The variable step size of MVS2\_IC technique is given as follows:

$$Step = N \left| \frac{dP}{dV - dI} \right| \quad (11)$$

III. SIMULATION RESULTS

To illustrate the efficiency of the four techniques of IC\_MPPT method, a simulation using Psim model is realized.

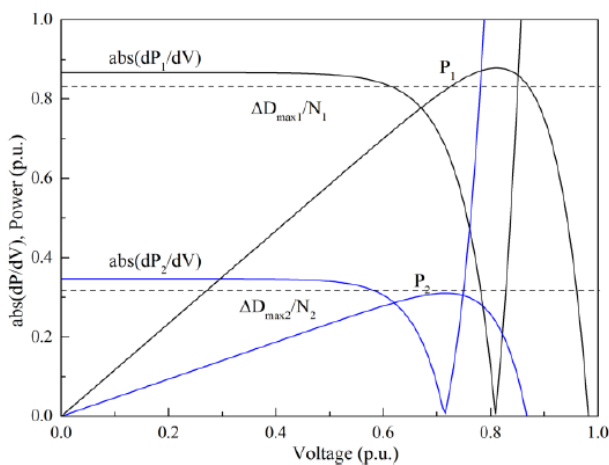

Fig. 6 Normalized power and slope of power versus voltage under different irradiation conditions.

The fixed step size is chosen to be 0,005 and the scaling factor  $N$  is adjusted as 0,001.

The results shown in Fig. 7, Fig. 8 and Fig. 9 are obtained for a fixed value of temperature (25°C) and a square oscillations form of solar irradiation whose switching between 800 and 1000 watts/m<sup>2</sup>.

For each curves, we note that the power curve extracted by the load joins the power curve of the panel PV to finally oscillate around it. The comparison between the four techniques shows that the techniques MVS2\_IC and

MVS1\_IC present a high response and a good convergence speed than the FS\_IC and VS\_IC techniques, this is due to the fact that the duty cycle of MVS2\_IC and MVS1\_IC techniques change with the change of the current which varies with the variation of the Atmospheric conditions.

IV. CONCLUSION

This paper study four techniques of IC MPPT algorithm: FS\_IC, VS\_IC, MVS1\_IC and MVS2\_IC these techniques track the maximum power point and controls directly the extracted power from the PV.

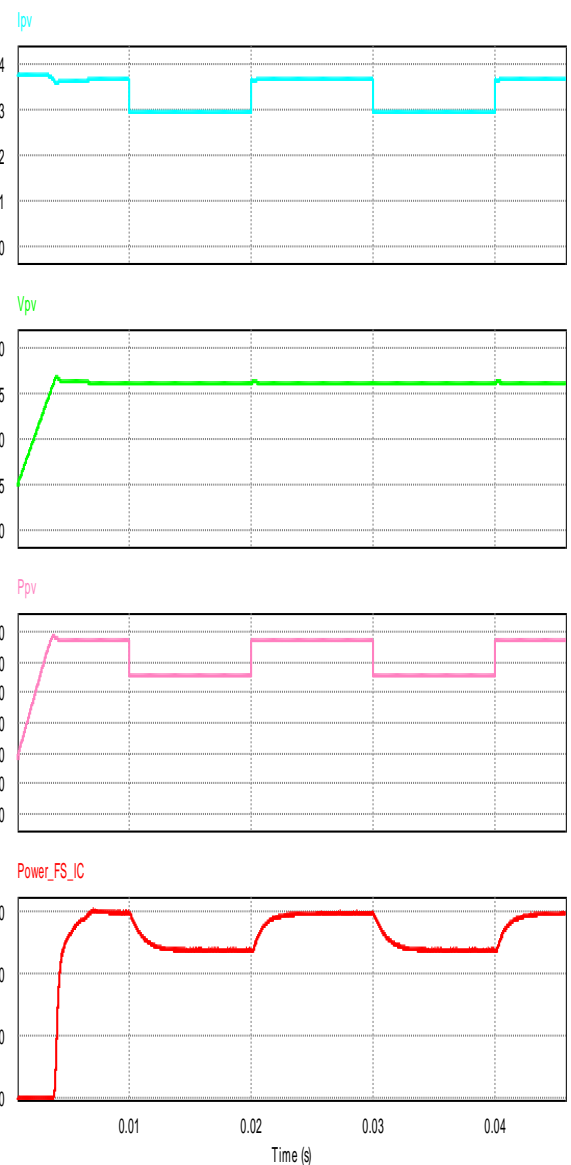

Fig. 7 Simulation results: Photovoltaic panel output current, photovoltaic panel output voltage, Photovoltaic panel output power and Photovoltaic power for DC/DC converter output

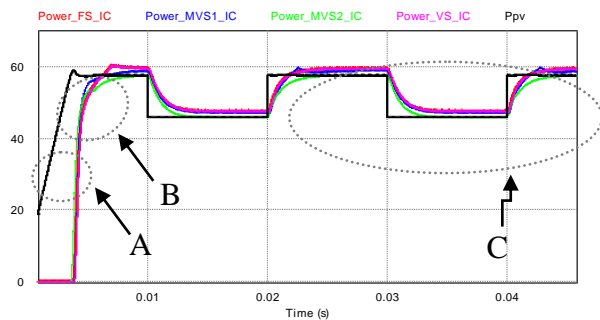

Fig. 8 Photovoltaic DC-DC converter output Power curves: FS\_IC (red curve), VS\_IC (magenta curve), MVS1\_IC (blue curve), and MVS2\_IC (green curve).

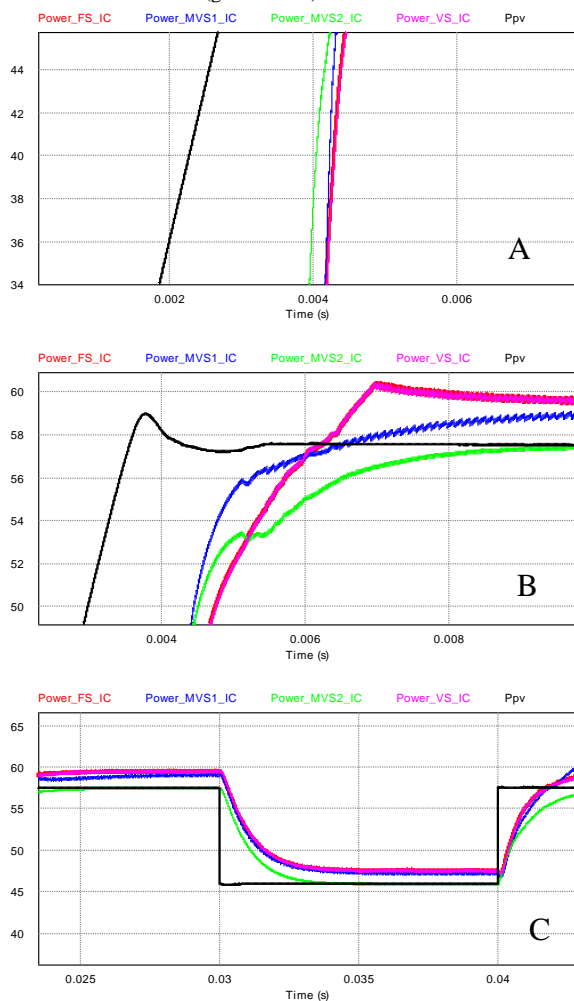

Fig. 9 Zoom in the part A, B and C of the Photovoltaic DC-DC converter output Power curves: FS\_IC (red curve), VS\_IC (magenta curve), MVS1\_IC (blue curve), and MVS2\_IC (green curve).

Compared to FS\_IC and VS\_IC techniques, The MVS1\_IC and The MVS2\_IC offer different advantages which are: good tracking efficiency, response is high and well control for the extracted power because of the adjusting of step sizes according to sun irradiation level using PV output current for increasing convergence speed and efficiency.

## REFERENCES

- [1] Y. Jiang, J.A .Abu Qahouq, M. Orabi, "Matlab/Pspice hybrid simulation modeling of solar PV cell/module", Applied Power Electronics Conference and Exposition (APEC), Twenty-Sixth Annual IEEE, 2011, pp. 1244-1250, ISSN 1048-2334.
- [2] K. H. Hussein, I. Muta, T. Hoshino, and M. Osakada, "Maximum photovoltaic power tracking: an algorithm for rapidly changing atmospheric conditions", IEE Proc. Generation, Transmission and Distribution, 1995, vol. 142, pp. 59-64.
- [3] D. Choudhary , A.R. Saxena,"DC-DC Buck-Converter for MPPT of PV System" , International Journal of Emerging Technology and Advanced Engineering, July 2014, Vol. 4, ISSN 2250-2459.
- [4] N. Femia, D. Granzio, G. Petrone, and M. Vitelli, "Predictive & adaptive MPPT perturb and observe method", Aerospace Electron Syst, IEEE Trans, 2007, Vol. 43, pp. 934-950.
- [5] N. Femia, G. Petrone, G. Spagnuolo, and M. Vitelli? "Optimization of perturb and observe maximum power point tracking method", Power Electron, IEEE Transaction, 2005, Vol. 20, pp. 963-973.
- [6] T. Esmam, P.L. Chapman, "Comparison of photovoltaic array maximum powerpoint tracking techniques", IEEE Trans. Energy Convers, 2007, Vol. 22, pp. 439-449.
- [7] V. Salas, E. Olías, A. Barrado, A. Lázaro, "Review of the maximum power pointracking algorithms for stand-alone photovoltaic systems", Sol. Energy Mater.Sol. Cells , Vol. 90, 2006, pp. 1555-157.
- [8] L. Yi. Hwa, H. Shyh-Ching, H. Jia-Wei, and L. Wen-Cheng,"A particle swarm optimization-based maximum power point tracking algorithm for PV systemsoperating under partially shaded conditions", IEEE Trans. Energy Convers, 2012, Vol. 27, pp. 1027-1035.
- [9] K. Ishaque, Z. Salam, M. Amjad, and S. Mekhilef, "An improved particle swarm optimization (PSO)-based MPPT for PV with reduced steady-state oscillation", Power Electron, IEEE Trans, 2012, Vol. 27, pp. 3627-3638.
- [10] M. Pedemonte, S. Nesmachnow, H. Cancela, "A survey on parallel ant colonyoptimization", Appl. Soft Comput. Vol. 11, 2011, 5181-5197.
- [11] E. Syafaruddin, T. Karatepe, Hiyama, "Artificial neural network-polar coordinated fuzzy controller based maximum power point tracking control underpartially shaded conditions", IET Renew. Power Gener, 2009, Vol. 3, pp. 239-253.
- [12] B. M. Wilamowski and X. Li , "Fuzzy system based maximum power point tracking for PV system". 28th Annual Conf. of the IEEE Ind.Electron. Society, 2002, pp. 3280-3284.
- [13] J.C. Cortes-Rios, E. Gomez-Ramirez, H.A. Ortiz-de-la-Vega, O. Castillo, P. Melin,"Optimal design of interval type 2 fuzzy controllers based on a simple tuning algorithm", Appl. Soft Comput, 2014, Vol. 23, pp. 270-285.
- [14] A. Safari and S. Mekhilef, "Simulation and Hardware implementation of incremental conductance MPPT with direct control method using Cuk converter", IEEE Trans.Ind. Electron., vol . 58, no. 4, Apr. 2011, pp. 1154-1161
- [15] S. R. Chafle, U. B. Vaidya,"Incremental Conductance MPPT Technique FOR PV System",2013, International Journal of Advanced Research in Electrical, Electronics and Instrumentation Engineering, Vol. 2, N 6.
- [16] J. H. Cho, W. Hong, "A Variable Step Size Incremental Conductance MPPT of a Photovoltaic System Using DC-DC Converter with Direct Control Scheme", Journal of the Korean Institute of Illuminating and Electrical Installation Engineers, 2013, Vol. 27, N 9, pp. 74-82.
- [17] A. Loukriz, M. Haddadi, S. Messalti," Simulation and experimental design of a new advanced variable step size Incremental Conductance MPPT algorithm for PV systems", ISA Transactions , 2015.
- [18] E. Baghazl , M. Melhaoui1 , M. F. Yaden1 and K. Kassmi1,"Photovoltaic System Equipped with a DC/DC Buck Converter and a MPPT Command Ensuring an Optimal Functioning Independently of System Perturbations" ,Physical Review & Research International vol. 4, 2014, pp. 80-90.
- [19] R. R. Sahoo, M. Singh,"Analysis of Variable Step Incremental Conductance MPPT Technique for PV System", IOSR Journal of

- Electrical and Electronics Engineering (IOSR-JEEE),2016, Volume 11, N 2, pp. 41-48.
- [20] E. M. Ahmed, M. Shoyama, "Stability Study of Variable Step Size Incremental Conductance/Impedance MPPT for PV systems", 8<sup>th</sup> International Conference on Power Electronics - ECCE Asia , 2011.
- [21] S. Abdourraziq, R. El Bachtiri, "A Variable Incremental Conductance MPPT Algorithm Applied to Photovoltaic Water Pumping System", International Journal of Electrical, Computer, Energetic, Electronic and Communication Engineering , 2015, Vol. 9, N 12, pp. 1354-1358.
- [22] F. Liu, S. Duan, F. Liu, B. Liu, Y. Kang, "A variable step size INC MPPT method for PV system", IEEE transaction on industrial electronics, 2008, vol. 55, N 7.
- [23] L. Joshi, "Incremental Conductance Based Maximum Power Point Tracking for PV Multi-string Power Conditioning System", International Journal of Emerging Technology and Advanced Engineering, 2013, Vol. 3, N 4, pp. 645-650.
- [24] B. A. ISALOO, P. AMIRI, "improved variable step size incremental conductance MPPT method with high convergence speed for pv systems", journal of Engineering Science and Technology, 2016, Vol. 11, N. 4, pp. 516 – 528.