

Design, Simulation and Implementation of a Photovoltaic-MPPT Performance Analyzer

AHMED AZI Alaeddine
 Department of Electrical Engineering
 University Mohamed Khider
 of Biskra-Algeria
 Email: alaelectro@hotmail.com

SAIGAA Djamel
 Department of Electronics
 University Mohamed Boudiaf
 of M'sila-Algeria
 Email: saigaa_dj@yahoo.fr

DRIF Mahmoud
 Department of Electronics
 University Mohamed Boudiaf
 of M'sila-Algeria
 Email: mhd.drif@gmail.com

Abstract—This paper is intended to contribute to the conceptual design of an electronic helping tool to analyze the performance of maximum power point tracking systems (MPPT). Indeed the MPPT is a device ensuring the connection between the generator and the rest of the PV conversion chain in order to transfer the maximum of the electric power from the generator. In this work, we present a new technique for analyzing MPPT performance. Its principle is based on the comparison between the P_{mp} that can be delivered by the PV generator and the actual power received by loads (power at MPPT output). The measurement of these powers is realized outdoor and in dynamic mode, i.e., the PV system is maintained in operation. The P_{mp} value is obtained by measuring only open circuit voltage and short circuit current of the PV array. In this paper, we will also present the developed device which this technique is implemented. The developed electronic device hardware implementation of this technique describes also. It should be noted that the peculiarity of this technique is the absence of measurement of climatic parameters (solar radiation and cell temperature).

Keywords—PV array, Maximum power, MPPT, Dynamic Measurement, Analysis.

I. INTRODUCTION

Energy is deeply implicated in each of the economic, social and environmental dimensions of human development. The amount of energy used defines the degree of development and civilization of countries. To compensate the shortage of energy, it is necessary to resort to sustainable energy systems by developing energy production based on renewable energy sources (such as solar energy, wind energy, etc.). Nowadays solar energy is the most abundant and inexhaustible renewable energy resource. In a minute, the sun can provide energy that is needed by the world in a year and in a day, it can provides energy more than that of the world's required consumption for 27 years [1]. This energy seems non-polluting, most promising and inexhaustible. In fact, the production of this energy is non linear and it varies according to the temperature and solar irradiation. Consequently, the operation point of the PV panel does not coincide with the Maximum Power Point (MPP) [2]. The random variation of MPP due to climate conditions in a direct coupling between PV array and loads can causes an initial lost in power consumption during the electric extraction from

the PV system that can be translated by a wasted power. To decrease the initial cost and improve energy-conversion efficiency remains the challenge. Therefore, it is necessary to track the maximum power point (MPP) of PV system [3].

The literature offers several MPPT techniques with a specific commands to extract maximum power from PV array, such as, hill climbing method, Perturb and Observe (P&O) method [4]-[5], Incremental Conductance (INC) [6], Neural Networks, Fuzzy Logic Controller, Particle Swarm Optimization, Genetic Algorithms and so on [7]-[8].The major problem with the electronic devices integrating MPPT techniques is the difficulty to validate their performance. In this sense a few studies addressing this issue are mentioned in the literature.

A static and dynamic test of an MPPT performance was performed, using different methods, as shown in the table below [9].

MPPT Measurement Methods	
Laboratory (Indoor)	Field (Outdoor)
Assessment under static conditions	Switching between MPPT and I-V tracer
Assessment under dynamic conditions	Using a calibrated reference module
Assessment of energetic efficiency	Sampling MPPT input at high speed
	Using manual mode to obtain I-V curve
Further tests	Analysing monitoring data

Tab 1. Overview on : MPPT Measurement Methods [9].

Therefore, a new method of performance analysis is presented in the section II which is based on the outdoor and online measurement of MPP.

A. Basic unit of photovoltaic generator

The electrical equivalent circuit representing the static behavior of a real PV cell is modeled by a current source in parallel with a diode, a shunt resistance and a series resistance [10]. This simplified model allows us to model the behavior of the electrical power source from the PV array.

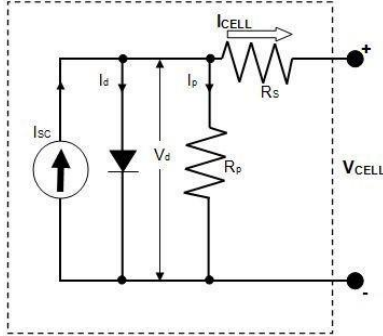

Fig 1. Equivalent circuit model of a PV cell.

B. The principle of seeking the maximum power point

The principle of these commands is to search the maximum power point (MPP) while ensuring perfect adaptation between the generator and the load to transfer maximum power.

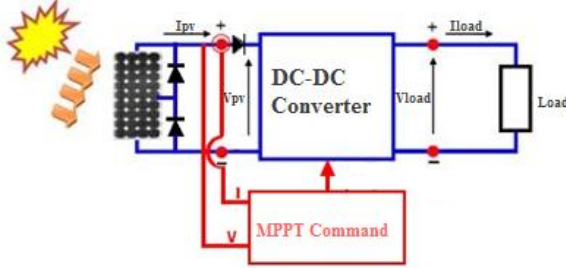

Fig 2. Elementary photovoltaic conversion chain.

For instance, we often encounter the problem of optimizing the outcome of the photovoltaic generator, which must be provided by the MPPT. It should be noted that there is little or almost no research according to the performance analysis of these systems (MPPT). The purpose in this paper is the proposal of a new analysis method which provides a performance parameter in real time (in dynamic mode) where the PV system is operating outdoor.

II. Concept and Principle of The Proposed MPPT Performance Analysis Technique

The occurrence of an abnormality is seen as a variation of the MPPT performance to reach the maximum power point for instant weather compared to a reference value for the same conditions cited. The analysis concept in this paper is to detect these variations to distinguish those resulting from failures of

those resulting from normal behavior, to decide whether these changes are actually significant compared to the uncertainties on the model and the reference and noise on the measured data.

A. Principle of the proposed technique

A system will be called MPPT-PA (Maximum Power Point Tracking Performance Analyzer) measure the values of the two powers by comparing component namely: the maximum power of PVG calculated by the MPPT (MPP) and the DC output power delivered to the load (Pload). These measurements are outcomes by the physical interconnection of our MPPT-PA system between the PVG and the MPPT for one side (far Upstream) and between the MPPT and load for the other side (far Downstream).

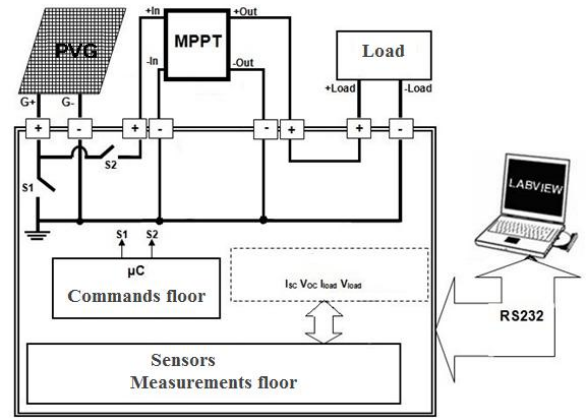

Fig 3. Block diagram of MPPT-PA system.

B. Maximum Power Reference (Pmp)

The maximum power reference (Pmp) is the maximum power that can be delivered by the PVG in an instant weather conditions. This power is the result of the arithmetic product of the optimum current (I_{mp}) and the optimum voltage (V_{mp}) as:

$$P_{mp} = I_{mp} \cdot V_{mp} \quad (1)$$

With :

$$I_{mp} = k_i \cdot I_{sc} \quad (2)$$

$$V_{mp} = k_v \cdot V_{oc} \quad (3)$$

C. Choice of multipliers K_i and K_v

It has been verified experimentally that there is a dependency between the short circuit current (I_{sc}) and the maximum current that can deliver a PVG (I_{mp}), and for the open circuit voltage (V_{oc}) and the PVG maximum voltage that can apply under certain climatic conditions [10].

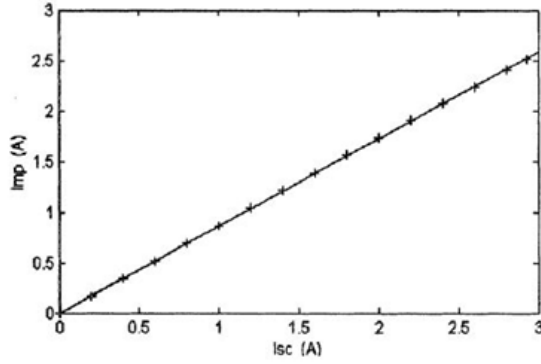

Fig 4. Dependence between "the current corresponding to maximum power" and "short circuit current" for an OFFC panel [10].

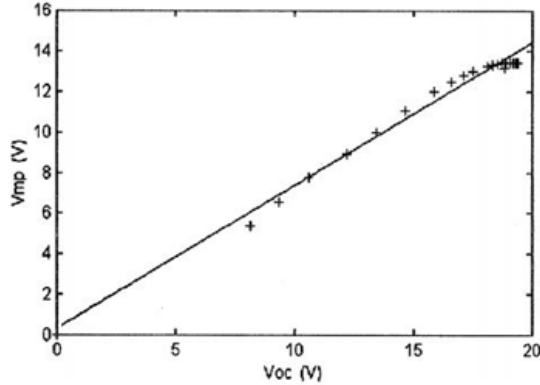

Fig 5. Dependence between "the voltage corresponding to the maximum power" and "open circuit voltage" for an OFFC panel [10].

K_i and K_v respectively represents the slopes of two straight curves. K_i and K_v are called respectively a current factor and a voltage factor and they are respectively equal to 0.86 and 0.71 [10].

By analogy, we can also define the product ($K_i * K_v$) by the form factor of PVGas:

$$FF = \frac{P_{mp}}{I_{sc} \cdot V_{oc}} = K_i \cdot K_v \quad (4)$$

D. Real power delivered by the MPPT

The real power delivered by the MPPT (P_{load}) is the result of the arithmetic product of the current (I_{load}) and voltage (V_{load}) as:

$$P_{load} = I_{load} \cdot V_{load} \quad (5)$$

E. Performance Factor

The performance factor (PF) is quite different from the energy efficiency of the MPP. In fact, it is the ratio of the power

extracted from the PVG (delivered to the load) (P_{load}) and the maximum power that can generate the PVG (P_{mp}), under the same climatic conditions

$$PF = \frac{P_{load}}{P_{mp}} * 100 \quad (6)$$

F. Principle of dynamic measurement method (Online measure)

The principle of the proposed method resolves the sampling of the short-circuit current I_{sc} and the open circuit voltage V_{oc} in a T period without a permanent disconnection of the MPPT from the PV conversion chain. Simply disconnect this MPPT during this period T_{sw} to take the open circuit voltage V_{oc} then short-circuit the PVG to pick up the short-circuit current I_{sc} then reconnect the MPPT to the PVG.

Given the temperature and radiation (two slow phenomena), these two main parameters that will modify the characteristic of a PV generator and which will cause a subsequent modification of the maximum power point, variations in time are negligible compared to the decoupling period of the MPPT .

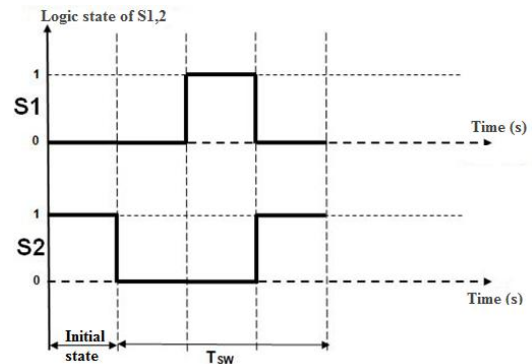

Fig 6. Logic states's chronogram of S1 and S2 for a T_{sw} period.

With :

$$S_{1,2} = \begin{cases} 1 : \text{Switch On} \\ 0 : \text{Switch Off} \end{cases} \quad (7)$$

STEP	S1	S2	Action
INITIAL	0	1	The MPPT is coupled to the PVG
1	0	0	Measuring the open circuit voltage V_{oc} (PVG is isolated)
2	1	0	Measurement of short circuit current I_{sc} current (PVG is shorted)
3	0	1	Measurement of current I_{load} and voltage V_{load} delivered to the load (MPPT is reconnected to the PVG)

Tab3.Switching scenario of S1 and S2 to ensure the online measure.

G. Measurement by redundancy

To ensure the reliability of our MPPT-PA system, we opt for the measurement by redundancy of the necessary values. This is resolved by the extent of N values of each parameter in one switching period T_{sw} and take the average of each parameter.

Parameters to measure	Average value
Short-circuit current I _{sc} (A)	$\overline{I_{sc}} = \sum_0^N \frac{I_{scn}}{N}$
Open circuit voltage V _{oc} (V)	$\overline{V_{oc}} = \sum_0^N \frac{V_{ocn}}{N}$
Current delivered to the load by MPPT I _{load} (A)	$\overline{I_{load}} = \sum_0^N \frac{I_{loadn}}{N}$
Voltage applied across the load by MPPT V _{load} (V)	$\overline{V_{load}} = \sum_0^N \frac{V_{loadn}}{N}$

Tab4. Calculate the average of the parameters's values for the analysis.

Equation for calculating the value N:

$$N = \frac{T_{sw}}{t_{one\ sample\ aquring}} \quad (8)$$

With :

t_{one sample aquring}: Time to take a single acquring of four variables's parametres

The particularity of this proposed strategy is that the measurement of climatic parameters including temperature and illumination is not indispensable.

H. Errors in Current, Voltage and Power

View that the performance factor is based on the relationship between the optimum power that can deliver the PVG and power delivering to load by the MPPT regulator, this one can lead to errors on the components of powers mentioned previously (currents and voltages) as:

$$\Delta I = I_{mp} - I_{Load} \quad (9)$$

$$\Delta V = V_{mp} - V_{Load} \quad (10)$$

$$\Delta P = P_{mp} - P_{Load} \quad (11)$$

III. HARDWARE IMPLEMENTATION

MPPT-PA system includes a conversion part a transmission part a control part and a power switching part. Our MPPT-PA is designed on the basis of a Arduino uno card a current sensor's

module a voltage divider as a voltage sensor's module and switch modules (relay).

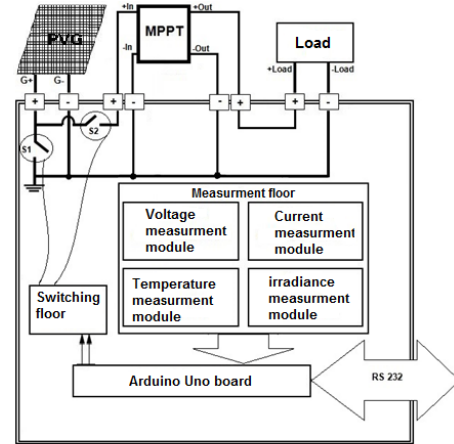

Fig 7. Block diagram of the modular structure of the MPPT-PA.

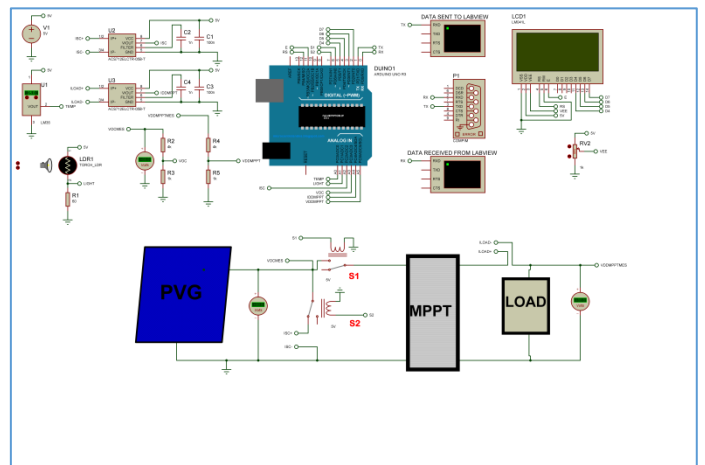

Fig 8. MPPT-PA Implementation using ISIS-PROTEUS

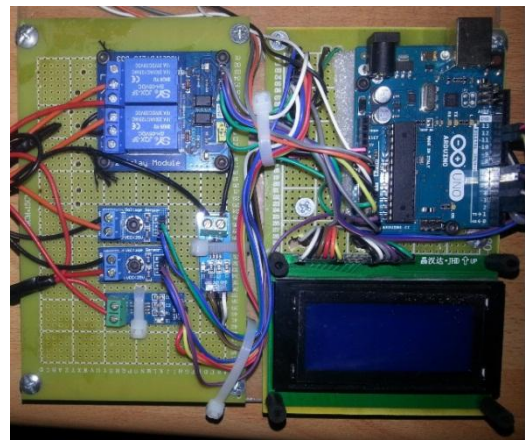

Fig 9. Developed MPPT-PA

IV. SOFTWARE IMPLEMENTATION

The GUI has been completely developed in Labview environment provided by National Instruments. This allows great flexibility in relation to the available functions and adapts the test bench to the needs of the user.

Communication between this interface and the hardware part will be through the serial port by developing a well-studied protocol to prevent loss of information that can impact the judgment with respect to the performance of the MPPT.

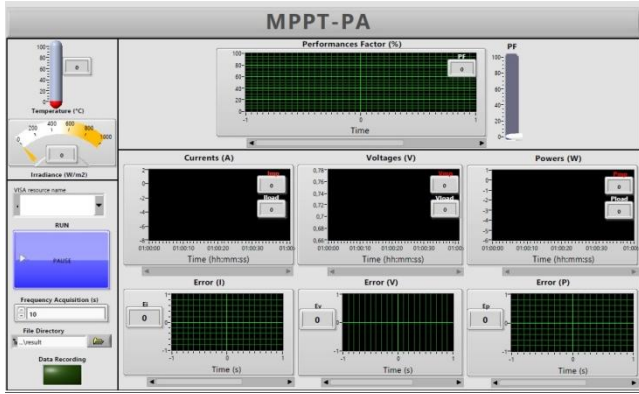

Fig 10. MPPT-PA GUI

It should be noted that the measure of two climatic parameters (temperature and irradiance) is made to have just an information on the conditions where the MPPT-PA device is working.

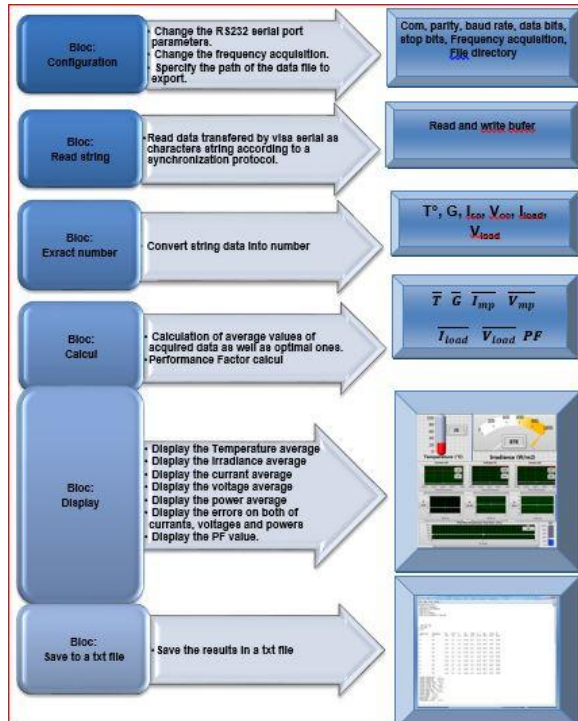

Fig 11. Schematic block diagrams constituting the MPPT-PA interface.

We used the Arduino Uno board it has the IC FTDI USB-to-serial. Instead of the usual serial port (DB9), it uses a Atmega8U2 programmed USB-to-serial converter. So this is to operate with a standard serial port RS232.

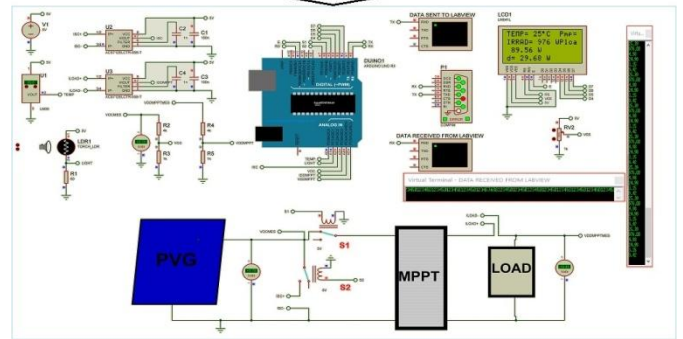
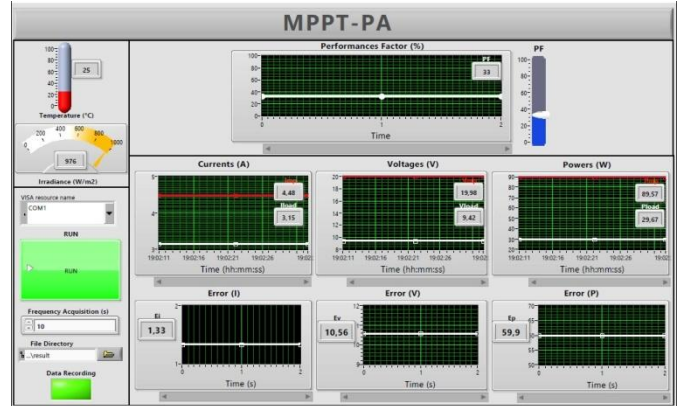

Fig 12 MPPT-PA Simulation using Isis Proteus and GUI under Labview

To save the parameters describing the performance of the analyzed MPPT and the results of measurement and calculation, we used a VI that acquires an output file format txt.

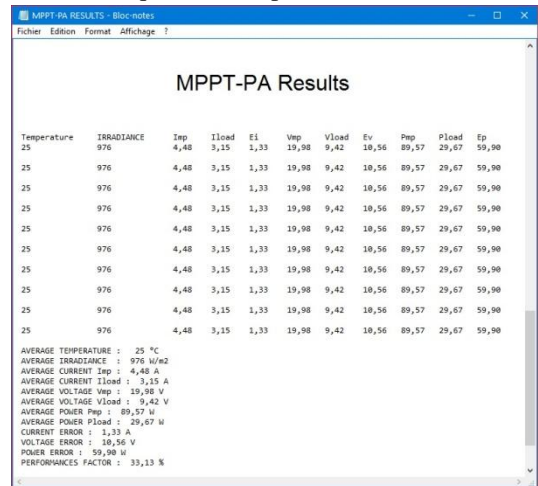

Fig 13. Output file in txt format

For example, we have established a significant PVG model using Isis-Proteus with a power of 35.1 W and $I_{sc} = 2.6$ A and $V_{oc} = 13.5$ V feeding a resistive load of 5.91Ω .

As at MPPT, we calculated a Ropt optimum strength corresponding to the point of maximum power.

The test results are displayed on the user interface and the output file.

V. CONCLUSION

In general, the photovoltaic conversion system include a photovoltaic generator and a power conditioning system with an MPPT control and a load. As the PV generator thereof, has a relative characteristic of power. The maximum power remains only a single operating point defined by a known voltage and a current, called the maximum power point. The change in the position of this point is expressed in terms of climate parameters (temperature and light). This requires a tracking system of this point so that the maximum power is continuously generated. The major problem of the MPPTs, is the difficulty to validate their performances. It should be noted that few studies (or almost no) addressing this problem are cited in the literature. Therefore, the main objective of this paper is the development of a new method of analysing based on the outdoor measurement of maximum power in dynamic mode and also the developpement of an electronic device that could serve as an analyzer helping tool.

This device, which we called MPPT-PA will be responsible for monitoring the MPPT performance through a user interface developed in LABVIEW.

A performance factor was calculated to give an idea about what percentage is this MPPT is performing.

It should be noted that the feature of this device is that the values of temperature and irradiance are not required in this process.

I. References

- [1] K. R. Chairmalakshmi, K. Shankar, M. Thangara, A. Abudhahir, "Performance Analysis of MPPT Algorithms for Enhancing the Efficiency of Spy PowerGeneration System : A Simulation Study," ICEVENT, 2013 Int Conf pp.1-5.
- [2] L. Abderezak, B. Aissa, S. Hamza "Comparative study of three MPPT algorithms For a photovoltaic system control," Information Technology and Computer Applications Congress (WCITCA), 2015 World Congress on pp.1-5.
- [3] S. Mulel, R. Hardas, and N. R. Kulkarni, "P&O, IncCon and FuzzyLogicImplemented MPPT Scheme for PV Systemsusing PIC18F452," *IEEE WiSPNET 2016 conference* pp.1320-1325.
- [4] F. Paz, and M. Ordonez, "Zero Oscillation and IrradianceSlopeTracking forPhotovoltaic MPPT," *IEEE Trans.Ind. Electron*, vol. 61, no. 11, pp.6138-6147, Nov 2014.
- [5] K.L. Lian, J.H. Jhang, and I.S. Tian, "A Maximum Power Point Tracking Method Based on Perturb-and-Observe CombinedWithParticleSwarm Optimization," *IEEE J. Photovoltaics*, vol. 4, no. 2, pp. 626-633, Mar. 2014.
- [6] K.S. Tey, and S. Mekhilef, "ModifiedIncremental Conductance Algorithm for Photovoltaic System Under Partial Shading Conditions and Load Variations," *IEEE Trans.Ind. Electron*, vol. 61, no. 10, pp.5384-5392, Oct 2014.
- [7] G. D. Cesare, D. Caputo, and A. Nascetti, "Maximum power point tracker forphotovoltaicsystemswithresistivelikeload," *Solar Energy*, vol. 80,no. 8, pp. 982-988, 2006.
- [8] E. Iyasere, E. Tatlicioglu, and D. M. Dawson, "Back-stepping PWM control for maximum power tracking in photovoltaicarraysystems," *In Proc .IEEE. ACC 2010*, pp. 3561-3565, Jul. 2010.
- [9] Jantsch, M., Real, M., Häberlin, H., Whitaker, C., Kurokawa, K., Blässer, G., ... &Verhoeve, C. W. G. (1997). *Measurement of PV maximum power point tracking performance*. NetherlandsEnergyResearchFoundation ECN.
- [10] Mohammad A. S. Masoum, Hooman Dehbonei, and Ewald F. Fuchs, Fellow, IEEE "Theoretical and Experimental Analyses of Photovoltaic Systems With Voltage-and Current-Based Maximum Power-Point Tracking", IEEE TRANSACTIONS ON ENERGY CONVERSION, VOL. 17, NO. 4, DECEMBER 2002.