

# Economical and efficient automatic sun tracking system used to handle solar parabolic concentrator

Safa Skouri<sup>#1</sup>, Salwa Bouadila<sup>#2</sup>, Sassi Ben nassrallah<sup>\*3</sup>

<sup>#</sup> *The Research and Technology Center of Energy,*

*The Thermal Processes Laboratory, Hammam Lif, B.P. 95, 2050 Tunis, Tunisia*

<sup>1</sup>safa.skouri@crten.rnrt.tn

<sup>2</sup>salwa.bouadila@crten.rnrt.tn

<sup>\*</sup>*Energetic department*

*National Engineering School of Monastir, ENIM*

*Street Ibn El Jazzar, 5019 Monastir, Tunisia*

<sup>3</sup>sassi.bennasrallah@enim.rnu.tn

**Abstract**— The purpose of this work is to presented an economical simple and efficient automatic system used to handled solar parabolic concentrator which has been designed constructed and test in the Research and Technology Center of Energy (CRTEen) in Tunisia a description of The four solar tracking system parts: mechanical design, electrical design, electronic design and a pilot control program.

**Keywords**— Azimuth angle, elevation angle, Sun traking system and controller.

## I. INTRODUCTION

Sun-tracking system plays an important role in the development of high solar concentration applications that directly convert the solar energy into thermal or electrical energy. Abdallah and Badran [1] deployed a sun tracking system for enhancing the solar still productivity. They compared a fixed and a sun tracked solar stills and they showed that the use of sun tracking increased the productivity for around 22%. Sungur [2] tested a PV panels with a two axes tracked sun system. He obtained 42.6% more of energy at 37°60, latitude (Konya, Turkey). Cruz-Peragón et al. [3] compared a fixed and a sun tracked solar electrical energy produced. They analyzed the annual energetic economical profitability to the two axes sun tracking device and they relived an energy advantage (higher than 20%) for most of the national territory. Arbab et al. [4] constructed a sun tracking system of a solar dish based on computer picture processing of a bar shadow. The operation of the system is independent respect to the initial configuration and the start time situation. Nuwayhid et al. [5] adopted both the open-loop and closed-loop tracking schemes into a parabolic concentrator attached to a polar tracking system. In the open-loop scheme, a computer acts as controller to calculate two rotational angles, as well as to drive the concentrator along the declination and polar axes. In the closed-loop scheme, nine light-dependent resistors (LDR) are arranged in an array of a circular-shaped “iris” to facilitate sun-tracking with a high degree of

accuracy. Escobar- Romero et al. [6] built and tested a solar parabolic concentrator prototype coupled to a turbine to generate electricity or to product steam. An experimental study has been done of spherical solar cooker with automatic sun tracking system designed and constructed.

They showed that the temperature inside the pan reached more than 93 °C [7]. In the present study, a Solar parabolic system controlled by an automatic sun traking system which could track the sun along both axes was designed and implemented. It has been presented and tested

## II. SOLAR ANGLES

The earth has two movements; it rotated around itself and around the sun that is why solar rays are characterized by two angles, these angles are named the azimuth angle and elevation angle.

### A. Solar azimuth angle

For a fixed point on the surface earth (for a specific longitude and altitude) the sun begins a race from east to west and moves draw this angle. This is the angle between the line that points to the sun and south. The angle is negative to the east and positive to the west. This angle is 0° at noon. It is probably close to -90° at sunrise and 90° at sunset, depending on the season. The azimuth angle is calculated according to the equation Eq. (1) [8].

$$\sin \alpha = \frac{\cos \delta \sin \omega}{\cos h} \quad (1)$$

### B. Solar elevation angle

The solar elevation angle is the angle between the line that points to the sun and the horizontal. It is the complement of the zenith angle. This angle is 0° at sunrise and sunset. The elevation angle is calculated using to the equation Eq. (6) [8].

$$\sin h = \cos \varphi \cos \delta \cos \omega + \sin \varphi \sin \delta \quad (2)$$

III. SUN TRACKING SYSTEM

The solar tracking system is divided into four parts: mechanical design, electrical design, electronic design and a pilot control program. The mechanical part designed in structure with two degrees of freedom in order to vary the inclination and orientation. Two motors and speed reducers are used to allow this support to revolve around the two axes. They are commanded with a pilot program and two encoders created to calculate the number of turns, that is, the number of degrees that each motor has displaced the SPC support.

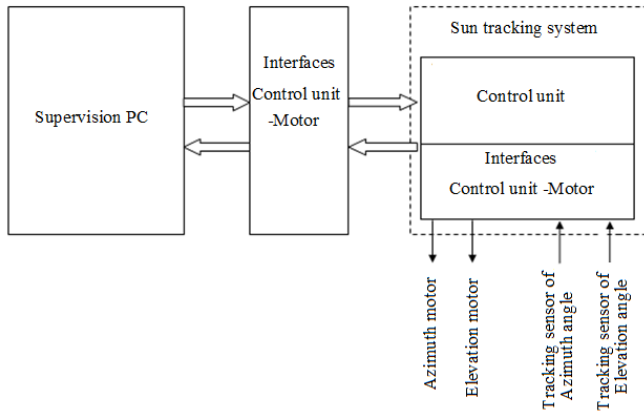

Fig. 1. Block diagram of sun tracking system

A. Mechanical structure

The solar parabolic concentrator SPC is mainly composed of a parabola provided with an absorber placed by three arms at the focal position. A reflector embedded in a nacelle rotatable around two axes: the horizontal axis (elevation angle) from the support supported by a mast and the second is the vertical axis (azimuth angle) and counterbalancing.

Two DC motors and speed reducers type WG075-40-E-F are used to decrease the engine rotational speed .

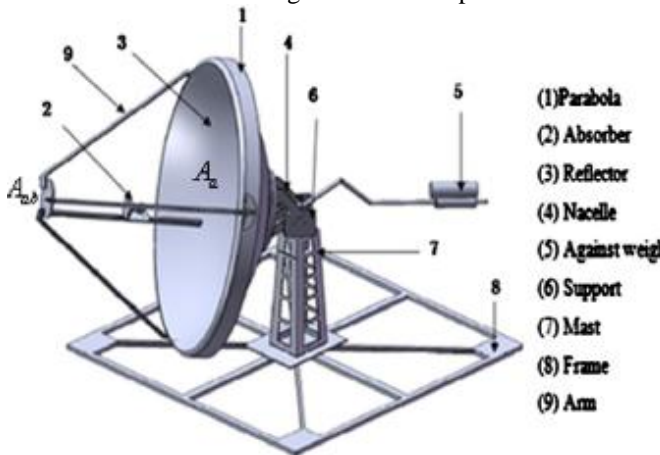

Fig 2. Structure of solar parabolic concentrator

B. Control unit

The role of the control unit is to treat and the manage the inputs and outputs of the sun tracking system in order to control the dish by two electric motors. That is why we chose

a programmable controller (PLC Siemens S71200-type CPU 1214C) to ensure these objectives. The choice of a PLC is due to its ability to operate in the environment of parabolic concentrator where it is exposed to dust, moisture, wind, heat.

C. Interfaces Control unit -motor

in order to ensure a simple and reliable control of electric motors in both directions , we thought of using a parabolic positioner ( VBOX ) . Indeed, operation and automation of part of positioning VBOX according to maximum sunshine is a cheap and interesting solution. The adaptation of the number of pulses shown on the display with the VBOX pulse number counted by the controller ensures that the deflection angle of the hub can not suffer errors.

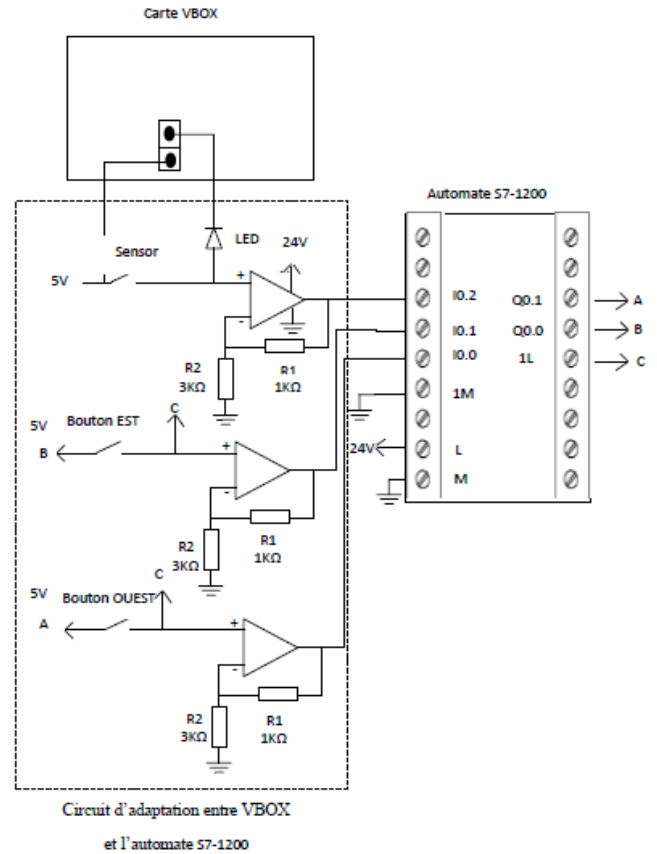

Fig 3. Adaptation of the programmable controller S7-1200 with VBOX

D. pilot control program

In each period, the controller must calculate the azimuth and the elevation angles from the astronomical and geometrical parameters. These two angles will be converted to a number of pulses .when the controller fixed the set point, it allows the rotation of the motor until the generated pulses reaches the set point value.

IV. EVALUATION OF THE SUN TRACKING SYSTEM

A. Cost estimation of the sun tracking system

The total sun tracking system is not expensive it composed essentially of (Two DC motors and speed reducers type WG075-40-E-F, programmable controller (PLC Siemens S71200-type CPU 1214C) with software and, two V box).The total price of all this materials is estimated to be equal to 1300 euro. If we compared it with commercial sun tracking system price that is so expensive we remarks a great difference between them .

**B. Experimental test**

In order to show the solar tracking system accuracy a comparative daily study of experimental and numerical solar angles has been done (Figs. 4 and 5). We noted that the numerical solar angles are determined by a pilot program. Values of the numerical and experimental solar angles (elevation and azimuth) are comparative. So the solar tracking system can guarantee a good solar pursuit even on cloudy days.

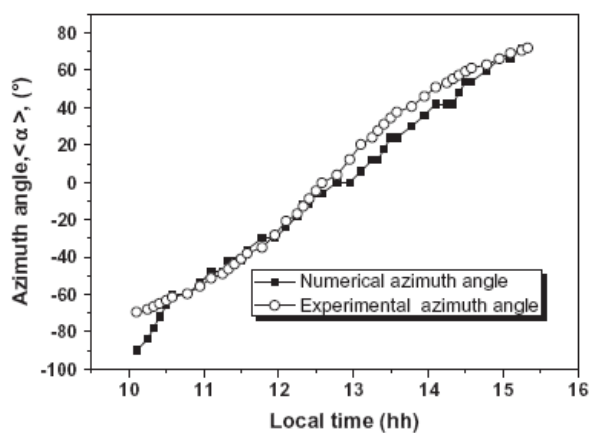

Fig. 4. Solar azimuth angle.

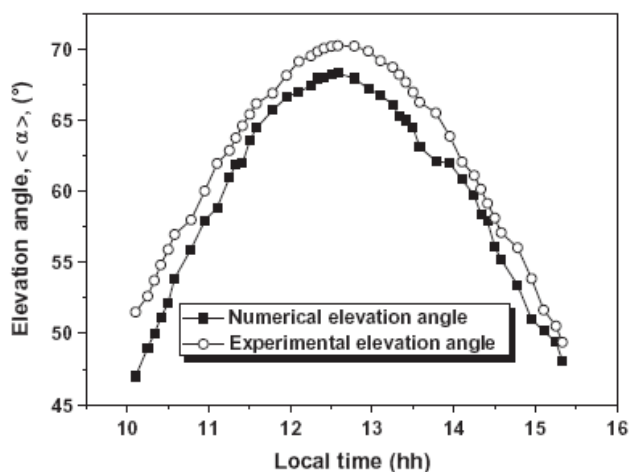

Fig. 5. Solar elevation angle.

**V. CONCLUSIONS**

This work is a contribution of a programmed sun tracking system used to ensure the movement of a solar parabolic concentrator around two axes. The main finding of the present study is the using of an economical efficient and more accurate two axes solar tracking system.

**ACKNOWLEDGMENT**

We thank the National Engineering School of Tunis for their collaboration to achieve this work.

**REFERENCES**

[1] S Abdallah, OO Badran. *Sun tracking system for productivity enhancement of solar still*. Desalination; Volume 220:pp 669–76., 2008

[2] C Sungur. *Multi-axes sun-tracking system with PLC control for photovoltaic panels in Turkey*. Renew Energy Volume;3 pp 1119–252009.

[3] F Cruz-Peragón, J Pedro, C Peláez, A Francisco, R López-García, JM Palomar. *An approach to evaluate the energy advantage of two axes solar tracking systems in Spain*. Appl Energy Volume 88 pp 5131–42,2011.

[4] H Arbab, B Jazi, M Rezagholizadeh. *Computer tracking system of solar dish with two-axis degree freedoms based on picture processing of bar shadow*. Renew Energy Volume 34 pp 1114–8. 2009;

[5] RY Nuwayhid, F Mrad, R Abu-Said. *The realization of a simple solar tracking concentrator for the university research applications*. Renew Energy ;Volume 24 pp 207–22, 2001.

[6] JFM Escobar-Romero, S Vázquez, Y Montiel, F Granados-Agustín, M Cruz-Martínez, E,Rodríguez-Rivera l. *Building a parabolic solar concentrator prototype*. J Phys Conf 2011.

[7] Z Li, D Tang , J Du, T Li. *Study on the radiation flux and temperature distributions of the concentrator receiver system in a solar dish/Stirling power facility*. Appl Therm Eng;Volume 31 pp1780–9, 2011.

[8] JM Chassériaux. *Conversion thermique du rayonnement solaire*. France: Agence Française pour la maîtrise de l'énergie; 1979.