

# PARTICLE SWARM OPTIMIZATION (PSO) FOR PHOTOVOLTAIC GENERATOR OPERATING UNDER PARTIALLY SHADED CONDITIONS

Banawaz Marwa<sup>#1</sup>, Zeddini Mohamed ALi<sup>\*2</sup>, Mansouri Mohamed Nejib<sup>#3</sup>

<sup>#</sup>ESIER, ENIM, TUNISIE

<sup>1</sup>Marwa Banawaz, e-mail : marwabanawaz@hotmail.com

<sup>2</sup>Mohamed Ali Zeddini, e-mail: daly\_enim@yahoo.fr

<sup>3</sup>Mohamed Nejib Mansouri, e-mail: mansouri.nejib@hotmail.fr

**Abstract**— This paper presents a detailed configuration of an association between a photovoltaic solar system that aims to inject active power into an electrical network and a parallel active filter whose task is to eliminate the disturbances present in this network. This modelling allows us to conclude that the characteristics of a photovoltaic generator are affected by solar light, temperature and shading. Or, with partially shaded conditions, we have multiple maximums in the P-V and I-V characteristics and there are different techniques who's defined to extract the maximum power point tracking (MPPT) as the perturb and observe (P&O) and the incremental of conduction (IncCond). But, these two algorithms fail to extract the global maximum power of the PV panel; however, they only extract the first maximum encountered either local or global. To resolve these problems, a technique based on particle swarm optimization (PSO) is studied and simulated under Matlab software. The results show that the PSO method has succeed to overcome these difficulties and reach the global MPP.

**Keywords**— photovoltaic solar system, Matlab, particle swarm optimization (PSO), parallel active filter, maximum power tracking (MPPT), perturb and observe (P&O), incremental of conduction (IncCond).

## I. INTRODUCTION

With the increasing interest about global environmental protection, the necessity to produce natural clean energy such as solar energy has received great concern as an alternative source of energy for the future, since it is clean, pollution-free and inexhaustible.

In Tunisia, most of the needed energy sources is imported from abroad. So, solar energy is one of the alternative energy. In addition of its excellent sunshine conditions, photovoltaic (PV) power generator is a good system to develop an important energy. In fact, if there is a good irradiance condition, the PV system can generate a maximum power efficiently, while an effective MPPT algorithm is used with the system.

Each type of PV module has its own specific characteristic corresponding to the surrounding condition such as temperature, irradiation and shading. Or, with partially shading, the P-V and I-V characteristics of PV panel show many maximums and this makes the tracking of maximum power point (MPP) a complicated problem. To overcome this problem, many maximum point tracking (MPPT) control algorithms have been presented such as perturb and observe (P&O), the incremental of conduction (IncCond), particle swarm optimization (PSO) and genetic algorithm as fuzzy logic (FL).

This paper describes the performance of PV module under shading conditions and PSO algorithm as a solution for MPPT and to command DC/DC converter.

## II. SYSTEM CONFIGURATION

The system consists of a PV generator, DC-DC and DC-AC converters connected to an electrical network as shown on figure1. The PSO base MPPT control is performed by adjusting the duty ratio of the DC-DC converter.

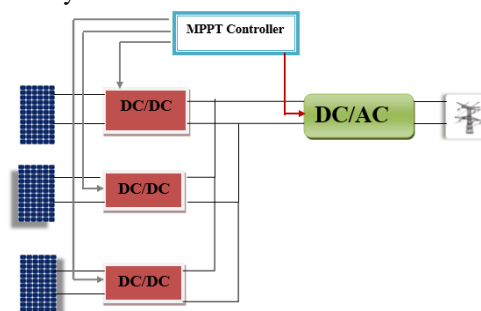

Fig.1 system configuration

## III. PV MODULE

In a photovoltaic distributed generation, a solar cell is the smallest unit of a PV generator. The connection in series or parallel between cells make a PV module, and further a PV array.

### A. Modelling of Solar Cell

PV cell is the basic component of PV module. it consists of a p-n junction fabricated in a thin layer of semiconductor. This cell is like p-n diode and their characteristics are also similar [1].

A solar cell equivalent electrical circuit can be represented by a single diode, as shown in fig.2, where the current source  $I_{ph}$  is the generated current from the light, the diode saturation current is  $I_0$ .  $R_s$ , series resistance, represents the various contact resistances in the system and  $R_p$ , parallel resistance, represents the leakage current of the semiconductor junction [2]

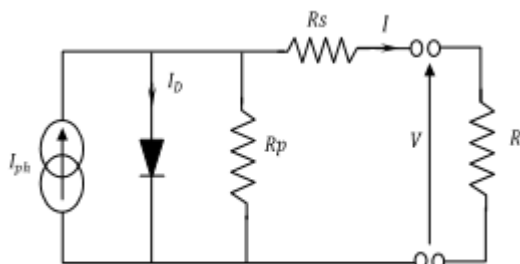

Fig.2 Solar Cell Equivalent Model

The mathematical model of this cell is given by the following expression:

$$I_{cell} = I_{ph} - I_0 \left( e^{\frac{V_{cell} + R_s I_{cell}}{V_t}} - 1 \right) - \frac{V_{cell} + R_s I_{cell}}{R_p} \quad (1)$$

Where  $I_{cell}$  and  $V_{cell}$  are the output current and output voltage of photovoltaic cell.

The table 1 resume all the notations of equation (1):

$I_{ph}$  depends mainly on the radiation and cell's temperature, which is expressed as:

$$I_{ph} = [I_{sch} + K_i(T - T_{STC})] \frac{G}{G_{STC}} \quad (2)$$

Where  $I_{sch}$  is the short circuit current at standard test conditions (STC), which are the cell temperature ( $T_{STC}=25^\circ C$ ) and  $G$  the irradiation on the cell surface (in watt per square meter ( $w/m^2$ ); or  $G_{STC}$  is the irradiation at STC ( $=1000 w/m^2$ ); and  $K_i$  is the short circuit current coefficient, usually provided by the cell manufacturer [3].

In addition, the saturation current  $I_0$  is influenced by temperature as shown in the following equation:

$$I_0 = \frac{I_{sch} + K_i(T - T_{STC})}{e^{\frac{V_{oc} + K_v((T - T_{STC}))}{V_t}} - 1} \quad (3)$$

$V_{oc}$  is the open circuit voltage at STC and  $K_v$  is the open circuit voltage coefficient; these values are available on the datasheet provided by module's manufacturer [3].

Table 1 Notations of Equation 1

$I_{ph}$	Current generation by absorption of photons at short circuit
----------	--

$I_0$	Diode reverse saturation current in the equivalent circuit of the module
$R_s$	Series resistance
$R_p$	Parallel resistance
$V_t = nKT/q$	Thermal voltage
n	Diode ideality factor ( $1 < n < 2$ )
K	Boltzman's constant ( $= 1.381 \times 10^{-23}$ J/K)
T	Temperature in kelvin
q	Electron charge ( $= 1.602 \times 10^{-19}$ C)

### B. Modelling of PV Module

PV cell produce a small power, so to generate the required voltage and power, PV cells are connected in series and parallel to form modules, modules are grouped into panels and the connection between panels make us to build up the entire PV array which can generate the desired current-voltage (I-V) and power-voltage (P-V) characteristics [3].

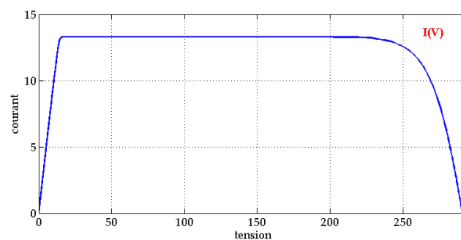

Fig.3 I-V curve

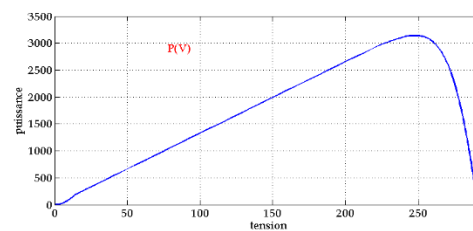

Fig.4 P-V curve

The mathematical model of PV array is shown by the following expression:

$$I = N_p \times I_{ph} - N_p \times I_0 \left[ e^{\frac{V + I \times (N_s/N_p) \times R_s}{N_s \times V_t}} - 1 \right] - \frac{V + I \times (N_s/N_p) \times R_s}{N_s \times V_t \times R_p} \quad (4)$$

Where  $N_s$  and  $N_p$  are series and parallel solar cells. The series connection will increase the output voltage, instead of the parallel connection will increase the output current.

To simulate equation (4), we used MATLAB/SimPowerSystem.

The curves I-V and P-V are shown respectively on figure3 and figure 4.

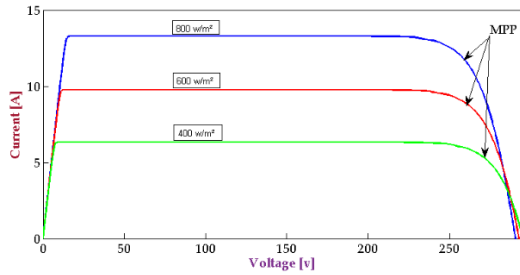

Fig.5 I-V curve for different values of radiation at 30°C

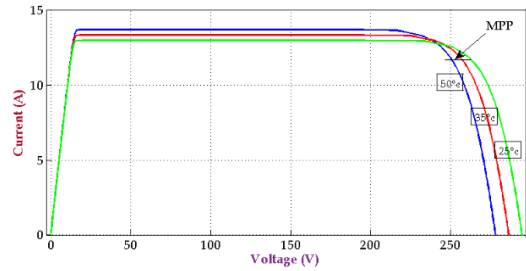

Fig.7 I-V curve with different values of temperature at 800w/m²

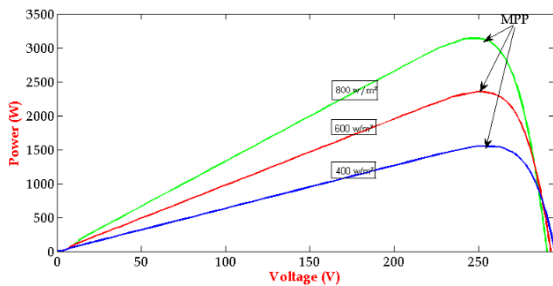

Fig.6 P-V curve with different values of radiation at 30°C

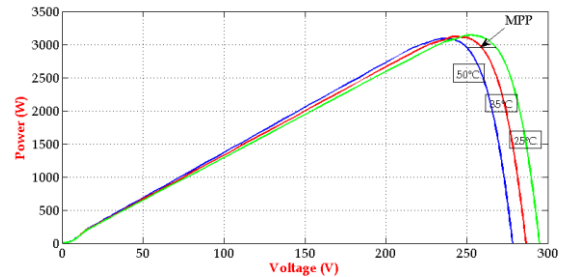

Fig.8 P-V curve for different values of temperature at 800w/m²

As shown in both graphs, we can illustrate 3 remarkable points:

- The point  $(V_{oc}, 0)$ , open circuit point, is the point where I-V curve meets axis and  $V_{oc}$  which is the open circuit voltage of PV module reflects the voltage of the module in the night when there is no generation of current ( $I=0$ ).
- The point  $(0, I_{sc})$ , short circuit point, is the point where I-V curve meets the voltage axis and  $I_{sc}$  which is the short circuit current is the greatest generated current value when the voltage is zero ( $V=0$ ).

The point  $(V_{mpp}, I_{mpp})$ , the maximum power point where the PV module produce its maximum power ( $P_{max}=I_{mpp} \cdot V_{mpp}$ ). In this case,  $I_{mpp}$  and  $V_{mpp}$  are, respectively, the maximum operating current and voltage of PV module. Or, when we connect a PV module directly to a load, the operating point is the intersection between the I-V curve of the PV module and the load curve. However, this operating point does not, usually, meet the maximum power point (MPP) of PV module. Also, as the maximum power point depends on cell temperature and solar radiation, which vary randomly, its position is continuously changing. moreover, it is very important to establish that the PV module is operating at its maximum efficiency because the most problem with PV energy generation system is low efficiency [4]. For that reason, many algorithms are used to overcome this problem, here we talk about maximum power point trackers (MPPT).

In general, the MPPT is realized by interposing the current and voltage measurements, the MPPT algorithms generates the optimal duty ration (D), ensuring to conserve the electrical quantities (V, I and P) at values corresponding to the

maximum power point [5].

### C. Influence of solar radiation and temperature

To show the effect of solar radiation and temperature, we used the modeling of our PV module with MATLAB/Simulink and simulate it with different values of radiation and temperature as shown in I-V curves on figure 5/figure 7 and P-V curves on figure 6/figure 8.

therefore, the I-V characteristics of a PV module depends strongly on solar radiation and temperature. As we can see in figure 5, the output current I of a PV module is extensively influenced by the variation in solar irradiance G, while the output voltage V stays almost constant. On the contrary, figure 7 shows that for a changing temperature the voltage varies widely while the current remains almost unchanged.

Furthermore, the P-V curve on figure 6 show how dependency of output power (P) on solar irradiance, and this proves the expected behavior of a device that transforms solar energy into electricity: the output power of a PV generator is considerably inflated for an increasing irradiance.

In the other side, figure 8 shows that the output power of PV module decrease by an increase in cell temperature. This can be explained by the dependency of the open circuit voltage ( $V_{oc}$ ) on the cell temperature as follows [6]:

$$V_{oc} = V_{oc,STC} + K_v(T - T_{STC}) \quad (5)$$

#### D. Shaded PV characterization

A PV array is composed of several PV modules connected in series and parallel, in order to produce the desired current and voltage. However, in real operating conditions, if the cells are slightly different or are not uniformly illuminated, we talk here about partially shaded conditions (PSC). A PV module is considered to be shaded if three or more of its cells are receiving lower than normal insolation [7].

In this case, the electrical behavior would be effected and the characteristics I-V will be influenced as shown in figure 9. Also, a new characteristic P-V as shown in figure 10.

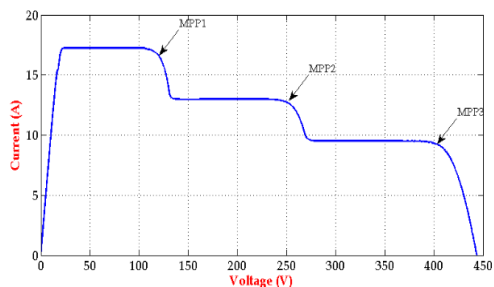

Fig.9 I-V under shaded conditions

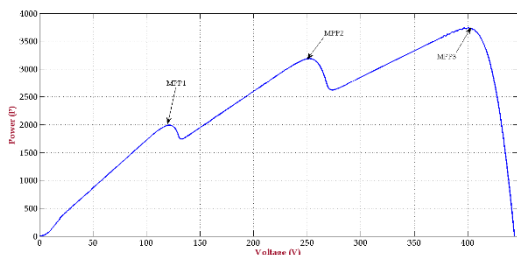

Fig.10 P-V curve under shaded conditions

It can be observed that number of peaks equal to the irradiance imposed for each shading pattern.

#### IV. MPPT CONTROL ALGORITHM

For normal conditions, when a PV module is directly coupled to a load, the I-V curve show an operating point which is the intersection of this curve with the load line (I-V relationship of load). This operating point can't follow the PV module 's MPP, the optimal adaptation can exist only at one particular operating point, called Maximum Power Point (MPP).

To overcome this problem, it's required to add an adaptation device, MPPT controller with a DC-DC Boost converter between the source and the load [8].

Moreover, the location of the MPP in the I-V plane is not established antecedently and always changes dynamically depending on irradiance and temperature. Also, as we can see in figure 5, there is a set of PV I-V curves under decreasing

irradiance at the constant temperature (30°C) and in figure 7, the I-V curves at the same irradiance but with different values of temperature. There is observable voltage deviation where the MPP occurs. So, the MPP controller is necessary to track the new modified maximum power point in its interrelated curve whenever temperature and/or insolation variation occurs.

Multifarious MPPT control techniques have been realized for this purpose these last decades [9].

All of them can be classified as:

- Voltage feedback based methods, where we compare the PV operating voltage with a reference voltage to produce the PWM control signal of a DC-DC.
- Current feedback based methods, where we use the PV module short circuit as an observation to measure the optimal current matching to the maximum power.
- Power based methods, which are established on iterative algorithm to track continuously the MPP over the current and voltage measurement of the PV module.

Among the various algorithms, the most widely used are the perturb and observe (P&O) and the incremental conductance method (IncCond) as well as variants of those techniques.

P&O is a simple algorithm which converges to the maximum power point (MPP) and oscillates around. But this method has a good result when the atmospheric conditions are constant or slowly changed.

IncCond is a good method to track the MPP of the PV module by comparing incremental conductance with instantaneous conductance. it's efficient under rapidly changing atmospheric conditions, but the response time to find the MPP is reduced.

Both of these algorithms are limited in partially shaded conditions, the presence of multiple peaks reduces the performance of the existing MPPT due to their inability to discriminate between the local and global maximum [10].

Over the years, many researches are developed to extract maximum power point under varying atmospheric conditions, but all of them are limited on shaded conditions, until the big revelation with the intelligent techniques. Among them, metaheuristics such as genetic algorithms (GA), particle swarm optimization (PSO), and shuffled frog leaping algorithms (SFLA) have validated their performance, in terms of robustness of MPPT, for various operational conditions in the case of partial shaded conditions [11].

##### A. Particle Swarm Optimization (PSO)

Inspiring by the social behavior of bird flocking and fish schooling, Eberhart and Kennedy developed the particle swarm optimization, in 1995.

A PSO algorithm controls a swarm of individuals (called particles) where each particle represents a candidate solution. Particles follow a simple behavior: imitate the success of neighboring particles and its own accomplished successes. The position of particle is consequently altered by the best particle in neighborhood,  $P_{best}$ , in conjunction with the best solution found by the particle itself,  $G_{best}$ , as shown in figure 11.

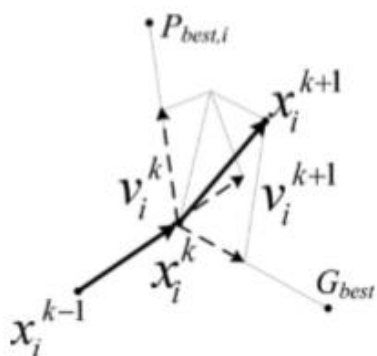

Fig.11 movement of particles in optimization process

To adjust the position of the particle, we use the following equation:

$$x_i^{k+1} = x_i^k + v_i^{k+1} \quad (6)$$

Where  $v_i$  is the velocity component and it represents the step size.

The velocity is calculated by using the following equation:

$$v_i^{k+1} = wv_i^k + c_1r_1\{P_{best,i} - x_i^k\} + c_2r_2\{G_{best} - x_i^k\} \quad (7)$$

$w$  is the inertia weight,  $r_1$  and  $r_2$  are random numbers between 0 and 1,  $c_1$  and  $c_2$  are the acceleration coefficients,  $P_{best,i}$  is the personal best position of particle  $i$  and  $G_{best}$  is the global best position of particles [12].

The PSO algorithm can be detailed step by step as following:

1. (PSO initialization): Initialize PSO parameters as initial position, swarm size, initial velocity and in this step we set up the iteration counter.
2. (fitness evaluation): Calculate the fitness of each particle.
3. (update positions and velocity of each particle): the position and velocity of each particle are updated using (6) and (7).
4. (convergence determination): check the convergence criteria if met, and if not the iteration counter will be increased by 1 and go to step 2.

These steps are shown on the flow chart in figure 12.

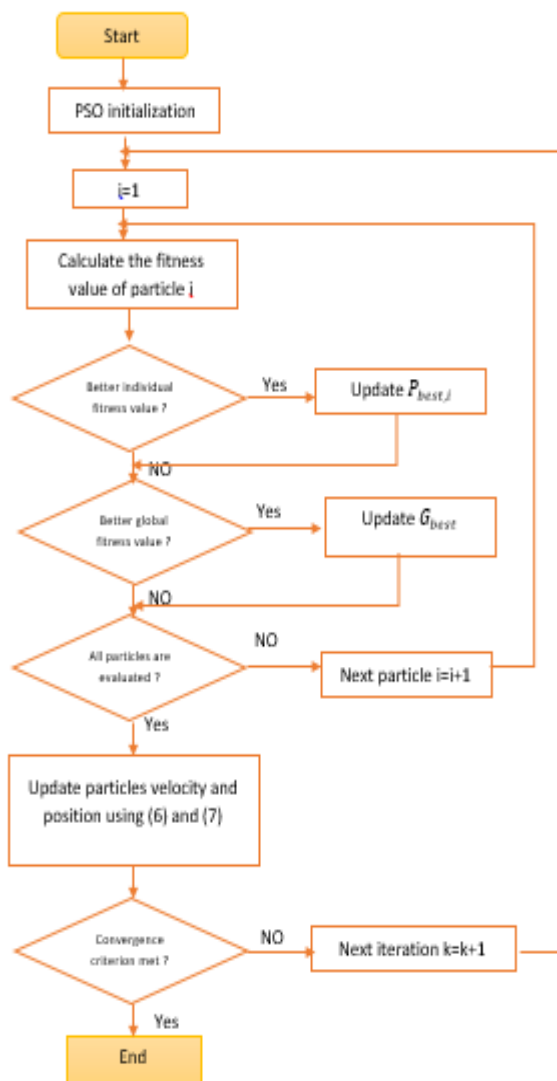

Fig.12 flow chart of standard PSO

### B. Application of PSO

The purpose of our research is to apply PSO algorithm to solve the problem of P-V curve wherein multiple peaks MPPs present. So, due to the uniqueness of this problem, the standard version of PSO algorithm will be mutated to meet the practical detail of PV operating under partial shading conditions.

Figure 13 show the new flow chart of the suggested PSO based MPPT technique, where the different steps will be marked with different colors. To more explain the new algorithm, all steps are detailed as following:

1. (parameter selection) the identification of parameters is necessary in this step, and on our system the particle position is defined as the duty cycle value  $d$

of the DC-DC converter, and the generated power  $P_{pv}$  is chosen as the fitness value evaluation function. Also, according to the literature, the number of MPPs in P-V curve for PV modules is equal to  $m$ , number of series connected PV cells [13]. So, the particle number  $N$  is chosen as the number of the series connected cells in the PV module.

2. (PSO initialization) the initialization of particles can be placed on fixed position in the space randomly except that there is an information about the location of the GMPP. Consequently, the initialization of the particles should be around it, and according to [14], the presence of peaks on the P-V curve is almost at multiple of 80% of the module open voltage  $V_{oc\_module}$ . So, particles are fixed on  $[D_{min}, D_{max}]$ .  $D_{min}$  and  $D_{max}$  are, respectively, the minimum and the maximum duty cycle of the DC-DC converter.
3. (fitness evaluation) in view of maximizing the generated power  $P_{pv}$ , the fitness value function is chosen as  $P_{pv}$ , so to calculate it, the measurement and the filter of PV voltage,  $V_{pv}$ , and current,  $I_{pv}$ , is necessary.
4. (update individual and global best data) here, the algorithm compares the new fitness value of particle  $I$  with the best fitness value in history  $P_{best,i}$  and if the comparison is positive, then the algorithm set the current value as the new  $P_{best,i}$ , and choose the particle, with the best fitness value, of all the particles as the  $G_{best}$ .
5. (update position and velocity of each particle) after the evaluation of all particles, the velocity and position of each particle should be updated, with the new equations as following [14]:

$$V_i(k+1) = w(k)V_i(k) + c_1(k)r_1(P_{best,i} - x_i(k)) + c_2(k)r_2$$

$$w(k) = w_{max} - \frac{k}{k_{max}}(w_{max} - w_{min}) \quad (9)$$

$w_{min}$  and  $w_{max}$  are, respectively, the lower and upper bounds of  $w$ , and  $k_{max}$  is the maximum admitted number of iterations.

$$c_1(k) = c_{1max} - \frac{k}{k_{max}}(c_{1max} - c_{1min}) \quad (10)$$

$$c_2(k) = c_{2max} - \frac{k}{k_{max}}(c_{2max} - c_{2min}) \quad (11)$$

$c_{1min}$ ,  $c_{1max}$  and  $c_{2min}$ ,  $c_{2max}$  are, respectively, the lower and upper bounds of  $c_1$  and  $c_2$ .

6. (convergence determination) the MPPT algorithm will stop and produce the obtained  $G_{best}$  solution, when two conditions will be reached, if the velocities of all particles become smaller than a threshold or if the number of iteration is attained.

## V. PARALLEL ACTIVE FILTER

Nonlinear loads produce distorted current waveforms in the electrical network. Therefore, the injected harmonics have several impacts on the system and loads connected to system.

As a solution to this solution, harmonic active filters are widely used in the system.

Parallel active filter is a converter used in order to compensate current disturbances as harmonics, unbalance and reactive power. Various topologies and configurations have been developed for this filter that highlight different forms of its compensation tasks [14].

In this paper, the current reference for active power filter is generated using fast zero phase detection (FZPD). This method is very simple as it has less number of calculations compared to other typical methods.

## VI. SIMULATION AND RESULTS

The proposed photovoltaic cells are not only able of providing extracted solar power to the power system. However, it also can considerably mitigate harmonic currents, which are peaked by non-linear loads. In consideration of establishing the effectiveness of the concepts discussed in this paper, a simulation using the environment SIMULINK in MATLAB is done.

Figure 14 shows source voltage waveforms completely sinusoidal and balanced. Figure 15 shows the load current which is nonlinear. Figure 16 shows the source current waveform deformed before filtering. Figure 17 presents the obtained current waveform. Figure 18 shows phase angle, between voltage and current, which is decreased by the method FZPD, and this the reason of reducing reactive power demonstrated on figure 19 where the reactive power is annulated with the active parallel filter. Figure 20 shows the power obtained by the MPPT, where the power is near the global power point.

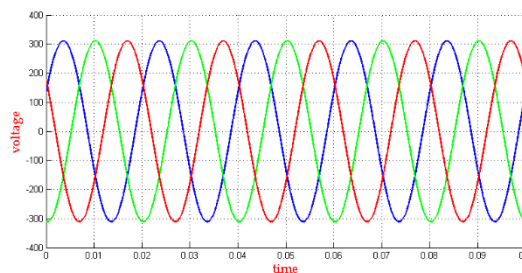

Fig.13 source voltage waveforms

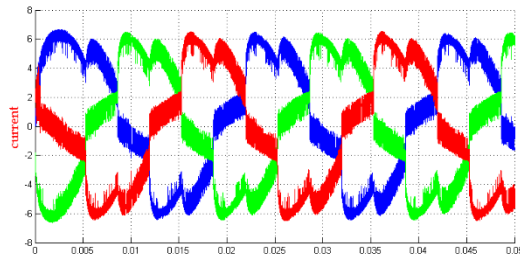

Fig.14 nonlinear load current

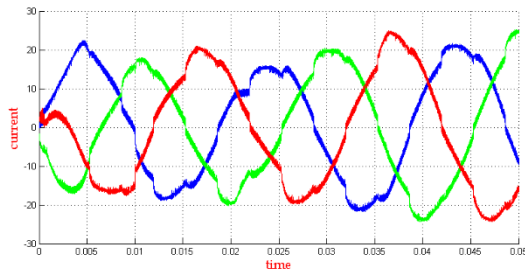

Fig.15 source current before filtering

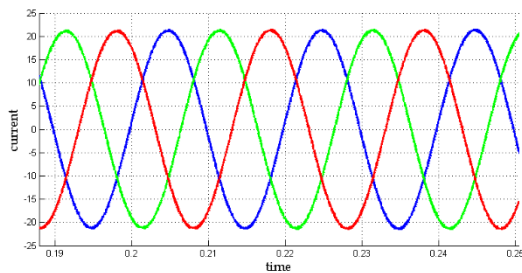

Fig.16 source current waveforms

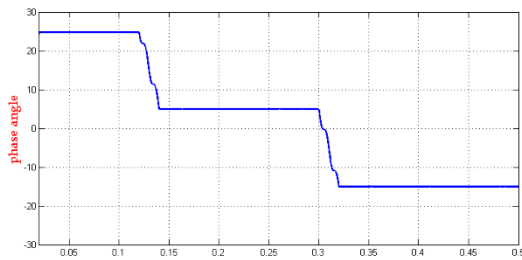

Fig.17 phase angle between V and I

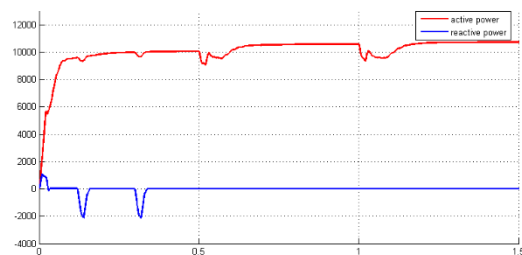

Fig.18 active and reactive power

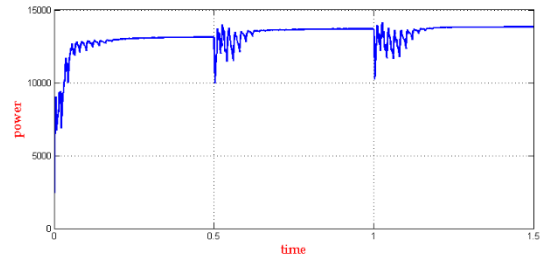

Fig.19 power

## VII. CONCLUSION

Photovoltaic power is, today, the favorable clean energy source. Therefore, to optimize its yield, we have proposed a direct connection of photovoltaic cells with parallel active power filter and MPPT based on PSO. From the results obtained, it is demonstrated that by applying the proposed system, photovoltaic power can be simply extracted by solar cells and injected into the grid by active parallel filter, which the principal duty is delivering the linear or nonlinear load with harmonic current and then controlled with the algorithm PSO to track the global maximum power point when multiple peaks exist in the P-V curve under partially shaded conditions.

Finally, and according to the obtained results, the proposed system seems to be an efficient solution but to upgrade it, we are studying to apply genetic algorithm to filter harmonic current.

## REFERENCES

- [1] Asim N, Sopian K, Ahmadi S, Saedfar K, Alghoul MA, Saadatian O, and al. 'A review on the role of materials science in solar cells'. *Renewable Sustainable Energy Rev* 2012, 5834–47.
- [2] Natarjan, Pandiarjan, "Photovoltaic Generator MATLAB/Simulink Model", (ICEES).2016,3<sup>rd</sup> conference on Electrical Energy Systems.2016.
- [3] Ishaque K, Salam Z, Syafaruddin, 'A comprehensive MATLAB Simulink PV system simulator with partial shading capability based two diode model', *SolEnergy* 2011, 2217-27.
- [4] Piegari L, Rizzo R. Adaptive perturb and observe algorithm for photovoltaic maximum power point tracking. *IET Renew Power Gener* 2010, 317–28.
- [5] Boualem Bendib, Hocine Belmili, Fateh Krim, 'A Survey of the most used MPPT methods: conventional and advanced algorithms applied for photovoltaic systems', *Renewable and Sustainable Energy Reviews* 45(2015), 635-648.
- [6] Hui-Feng Tsai, Huan-Liang Tsai, 'Implementation and verification of integrated thermal and electrical models for commercial PV modules', *Solar Energy* 86 (2012) 654-665.
- [7] Hiren Patel and Vivek Agarwal, 'Maximum Power Point Tracking Schema for PV systems Operating Under Partially Shaded Conditions', *IEEE TRANSACTIONS ON INDUSTRIAL ELECTRONICS*, vol.55, NO.4, April 2008.
- [8] Mohamed M.Algazar, Hamdy Al-monier, Hamdy Abd El-Halim, Mohamed Ezzat El Kotb Salem, "Maximum Power Point tracking using Fuzzy logic control", *Renewable Power and Energy systems* 39 (2012) 21-28.

- [9] Haithem Chaib, Anis Sakly, "Comparison between P&O and PSO Methods based MPPT Algorithm for photovoltaic systems", 16<sup>th</sup> international conference on sciences and techniques of automatic control & computer engineering –STA 2015, Monastir, Tunisia, December 21-23, 2015.
- [10] Volter, Quasching, Rolf, Hanitsch, "Numerical simulation of photovoltaic generator with shaded cells", Proceeding of the 30<sup>th</sup> universities Power, engineering conference, 2008, pp 583-586.
- [11] Yousra Shaik, Mouna Ben Smida, Anis Sakly, Mohamed Faouzi Mimouni, "Comparison between conventional methods and GA approach for maximum power point tracking of shaded solar PV generators", solar energy 90 (2013) 107-122.
- [12] Kashif Ishaque and Zainal Salam, "A deterministic Particle Swarm Optimization Maximum Power Point Tracker for Photovoltaic System Under Partial Shading Conditions", IEEE Transactions on industrial, Electronics, vol-60, N8. August 2013.
- [13] H. Patel and V. Agarwal, "MATLAB-based modeling of partial shading and different orientation of photovoltaic modules", IEEE Trans. Energy convers, vol.23, no.1, pp 302-310, Mar. 2008.
- [14] Brahim Berbaoui, Samira Dib, Rachid Dehini, "grid-connected photovoltaic power systems and power quality improvement based on active power filter" TELKOMIVIKA Indonesian journal of electrical engineering, vol.12, NO.8, August 2014, pp5861-5868.